



Nirve Rear Rack Installation Instructions

© June 2009 Nirve Sports, Ltd. All rights reserved. 15401 Assembly lane, Huntington Beach, CA 92649 USA 888-296-4783 www.nirve.com

Parts Included

- 1 Rear rack with spring clip
- 2 Adjustable arm assemblies (arm, bracket, bolt, nut)
- 2 Bolts
- 2 Washers

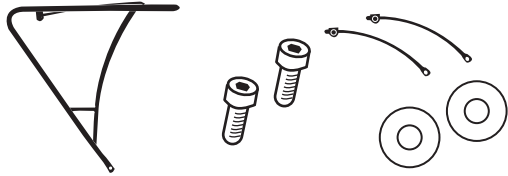

Tools needed

- #4 Allen wrench
- #5 Allen Wrench
- #10 Hex wrench (or adjustable crescent wrench)
- 5mm x .8 tap bolt and washer (x4) (if not already provided on bicycle)

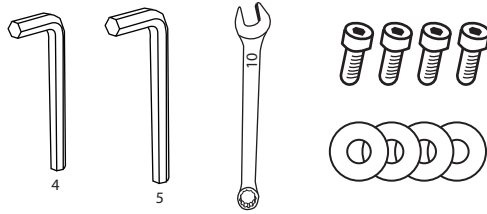

- 1.** Determine the best placement and position of the adjustable arms for your bicycle - Holes A or B.

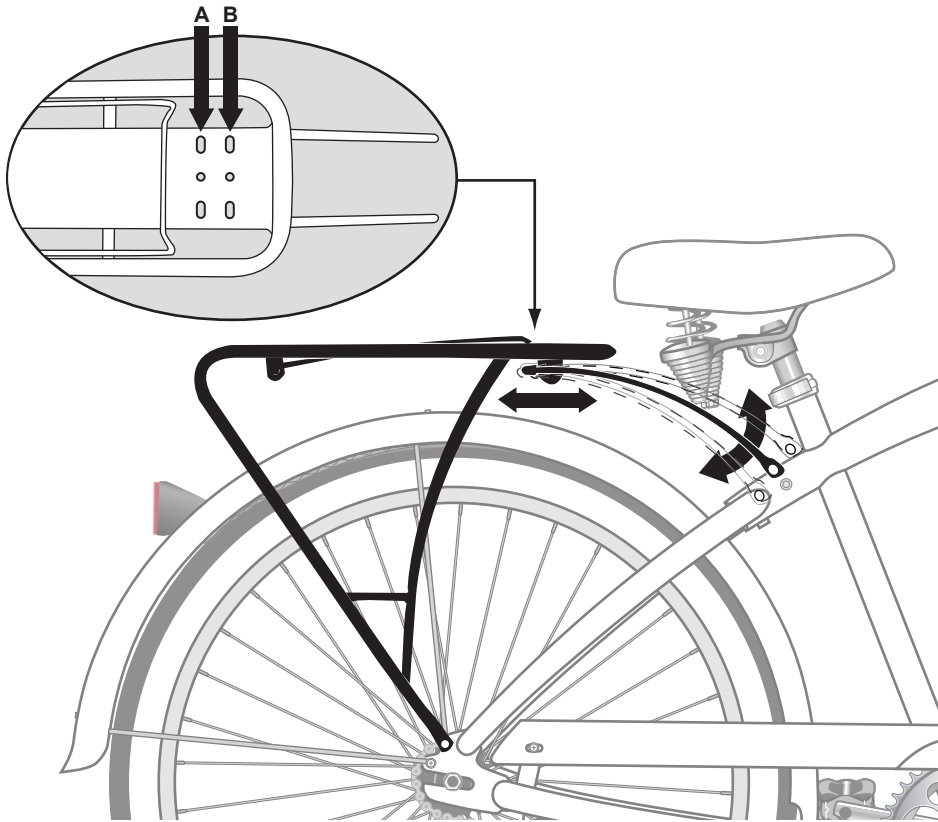

- 2.** Attach adjustable arm assembly to the rack. The arms should be on the outside of the bracket assembly. Do not tighten completely. Arms should remain loose so the rack can fit best on bicycle.

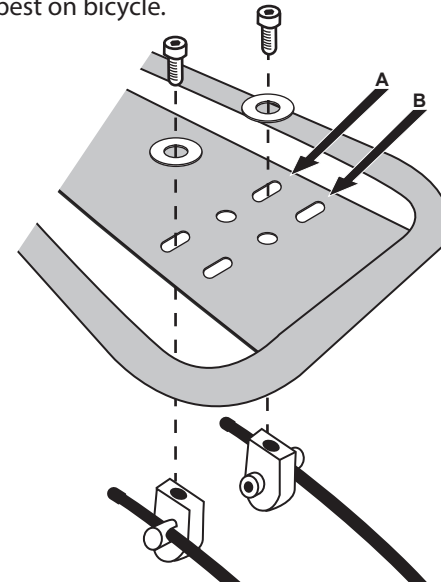

- 3.** Attach rack to the bicycle.
(If the bicycle already has a fender brace in the dropout eyelet, remove the bolt and washer and reattach with both the rack and fender brace in the same eyelet.)
If available, use existing hardware on bicycle. If hardware (bolts and washers) are not included on the bicycle, consult with the bicycle owner's manual or your local bike shop for proper fit. Nirve bicycles use 5mm wide x 80mm TPI bolt on the rear drop out and upper monostay.

TOP

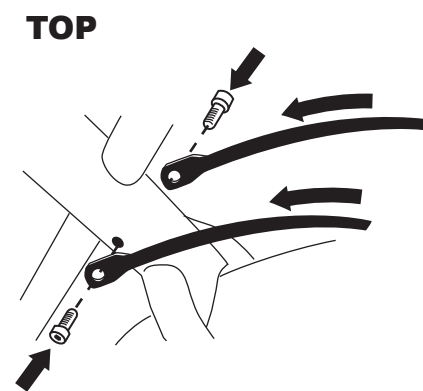

BOTTOM

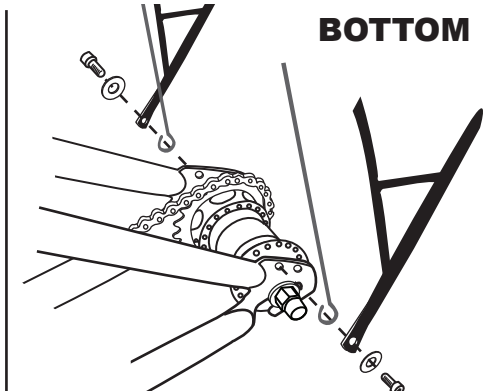

- 4.** Tighten all hardware so that the rack is parallel with the ground.